

SECTION 12-02 Heating and Defrosting

SUBJECT	PAGE	SUBJECT	PAGE
ADJUSTMENTS		REMOVAL AND INSTALLATION (Cont'd.)	
Air Door Control Cable	12-02-17	Blower Switch	12-02-6
Control Cable Adjustment	12-02-16	Control Cables	12-02-6
Function Selector Cable	12-02-16	Defroster Ducts	12-02-13
Function Selector Rod	12-02-16	Defroster Tubes and Side Demister Tubes	12-02-13
Temperature Control Cable	12-02-17	Heat Ducts, Rear Seat	12-02-14
DESCRIPTION		Heater Case	12-02-9
Air Distribution	12-02-2	Heater Control Panel	12-02-5
Airflow	12-02-1	Heater Core	12-02-10
Blower Switch	12-02-4	Heater Hoses	12-02-12
Temperature Control	12-02-2	Heater Tube, LH	12-02-15
DIAGNOSIS AND TESTING	12-02-5	Instrument Panel Ducts	12-02-14
REMOVAL AND INSTALLATION		Register, RH Side	12-02-13
Air Inlet Duct	12-02-14	Registers, LH Side and Center	12-02-12
Blower Case Assembly	12-02-8	SPECIFICATION	12-02-17
Blower Motor	12-02-7	VEHICLE APPLICATION	12-02-1
Blower Motor Resistor	12-02-7		

VEHICLE APPLICATION

Capri.

DESCRIPTION

The heating system consists of a blower case, a heater case and various air distribution ducts.

The blower case is mounted to the dash panel behind the instrument panel on the passenger side. The blower case houses the blower motor, blower motor resistor and the recirculation / fresh air door.

The heater case is mounted to the dash panel behind the center of the instrument panel. The heater case houses the heater core, air discharge doors and air temperature door. All air control doors are cable-operated from the control panel located in the center of the instrument panel.

Airflow

The heater assembly is a blend air system, receiving outside air or recirculated air depending on the position of the recirculation / fresh air door. The door is controlled by a cable from the control panel. Air enters the blower case and is forced by the blower motor into the heater case assembly. The air passes through the heater core or can bypass it depending on the position of the temperature control door. The air is then directed to the various registers according to the position of the vent and defroster doors.

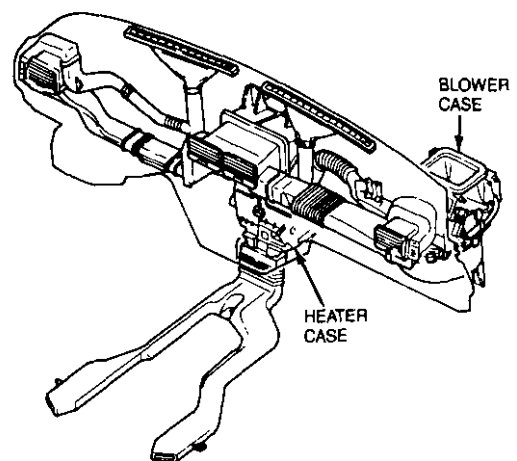

K14828-A

DESCRIPTION (Continued)

Temperature Control

A temperature blend door directs air to flow through the heater core for heating or to bypass the heater core for cooling. It is controlled between COOL and WARM (blue and red) by the temperature lever of the control panel. Positioning the temperature lever in any position between COOL and WARM (blue and red) causes the air temperature door to direct more or less air through the heater core in order to achieve the desired temperature.

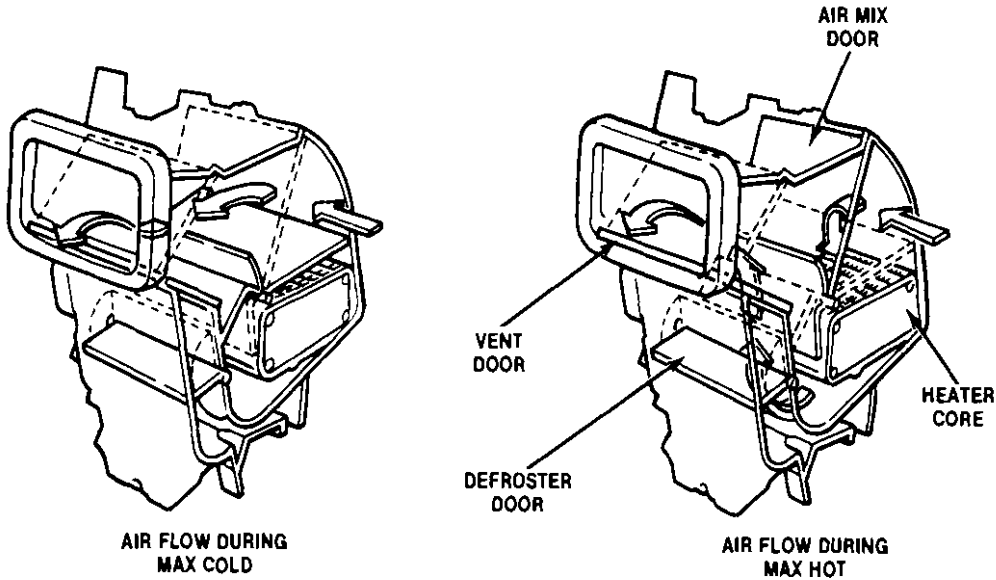

K10327-A

Air Distribution

The blended warm and cool air is distributed to the defroster outlets, the instrument panel registers or to the floor distribution outlets according to the position of the air discharge doors. The doors are controlled by a cable from the control panel.

When the function selector lever is in the VENT position, all airflow is directed to the instrument panel registers.

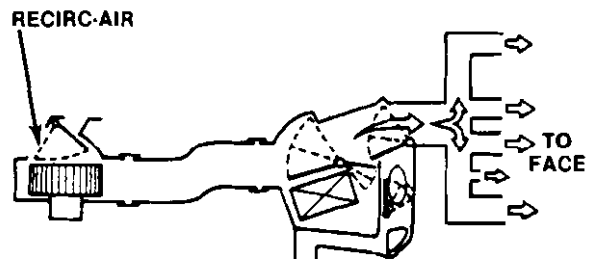
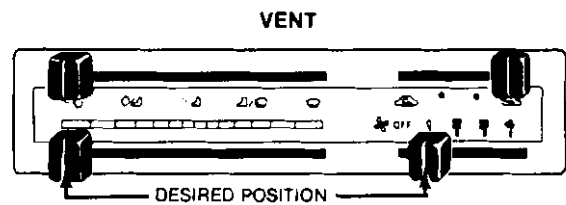

K10328-A

DESCRIPTION (Continued)

When the function selector lever is in the BI-LEVEL position, airflow is equally directed to all registers.

BI-LEVEL

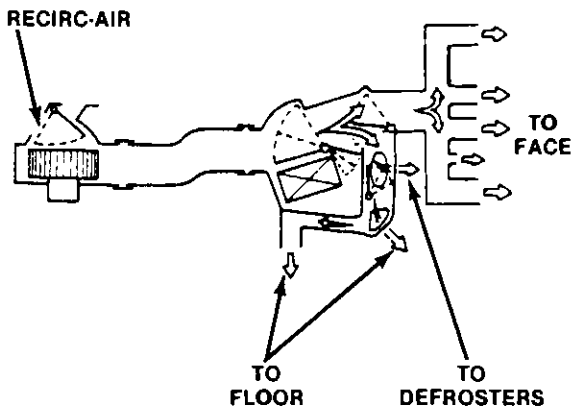
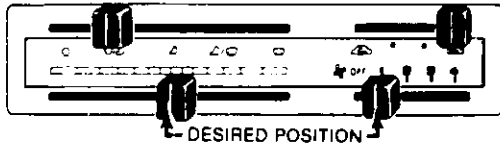

K10329-A

When the function selector lever is in the HEAT position, most of the airflow is directed to the floor registers with a small amount directed to the defrost registers.

NOTE: Objects stored under the front seats may restrict heat to the rear of the vehicle.

HEAT

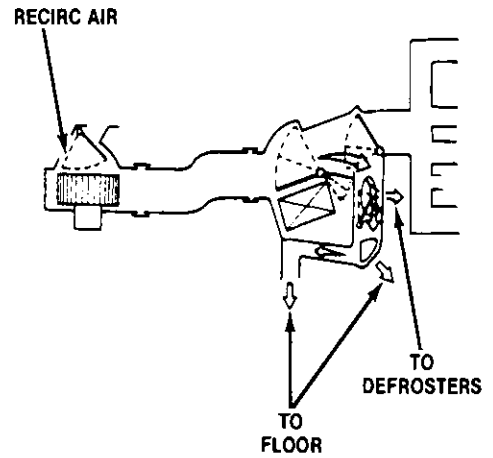
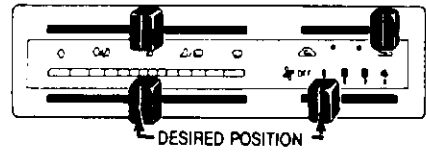

K10330-A

DESCRIPTION (Continued)

When the defrost selector lever is in the HEAT/DEFROST position, airflow is directed equally to the floor and defroster registers.

HEAT/DEF

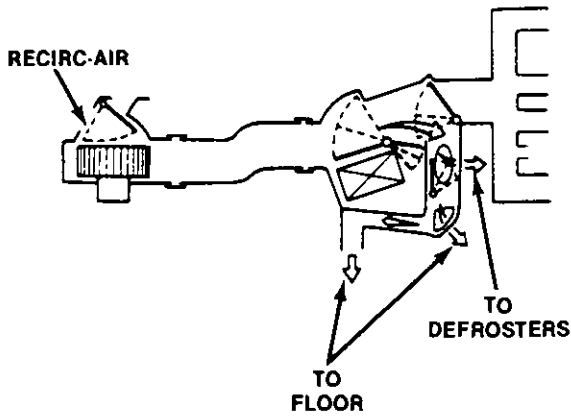
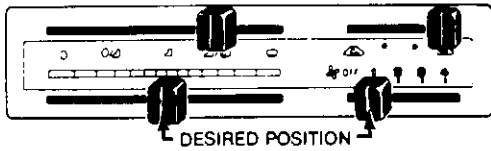

K10331-A

When the function selector lever is in the DEFROST position, all airflow is directed to the defroster registers.

DEF

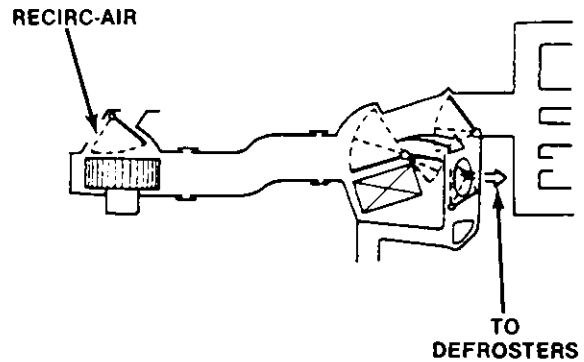
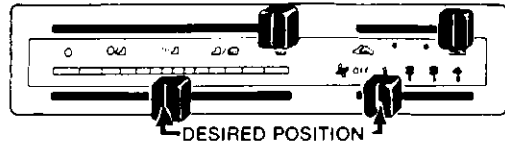

K10332-A

Blower Switch

Blower motor operation is controlled by a five position switch in the lower right corner of the control panel. The switch is identified by a fan blade symbol on the face of the control panel. This switch directs the blower motor ground circuit current through, or around, the resistor assembly coils, to control blower speed.

When the switch is in the OFF position, the motor ground circuit is open and the blower motor does not operate.

With the blower switch in position 1, current flow from the blower motor is restricted by three resistor coils in the resistor assembly.

When the switch is moved to position 2, one of the resistor coils is bypassed out of the circuit and current flow from the blower motor is restricted by two resistor coils.

When the switch is moved to position 3, two of the resistor coils are bypassed out of the circuit and current flow from the blower motor is restricted by only one resistor coil.

DESCRIPTION (Continued)

When the switch is moved to position 4, all three resistor coils are bypassed out of the circuit and there is a direct ground circuit for the blower motor.

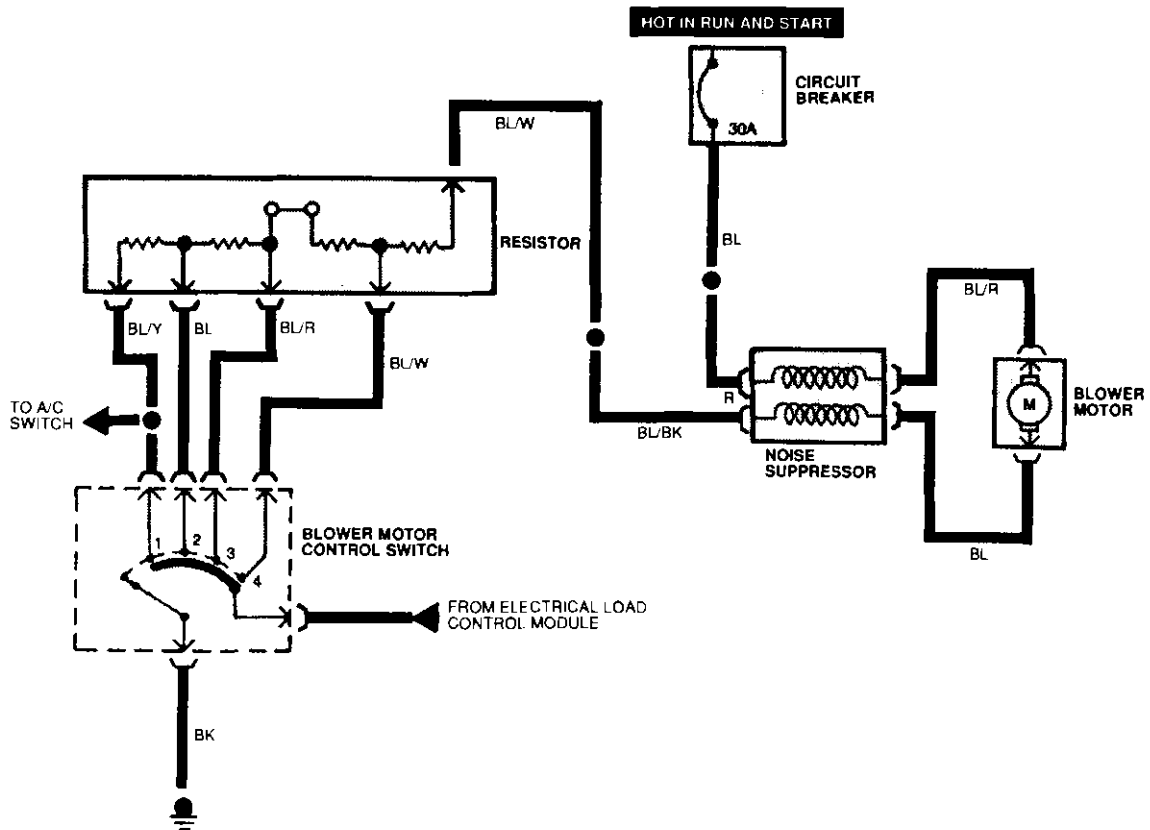

L8309-A

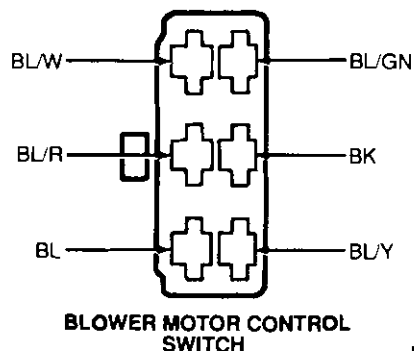

L8260-A

DIAGNOSIS AND TESTING

Refer to Section 12-00.

REMOVAL AND INSTALLATION

Heater Control Panel

Removal

1. Disconnect negative battery cable.
2. Remove storage compartment.
3. Remove heater / radio bezel.
4. Remove heater control panel retaining screws.
5. Lower glove compartment past its stop and remove glove compartment upper support.
6. Disconnect air door control cable.
7. Disconnect function selector cable at heater assembly.
8. Remove LH center carpet panel.
9. Disconnect temperature control cable at heater assembly.
10. Pull heater control panel from instrument panel far enough to gain access to electrical connectors and disconnect. Use caution so as not to damage control cables.

REMOVAL AND INSTALLATION (Continued)

11. Remove two screws and heater control panel assembly with cables attached.

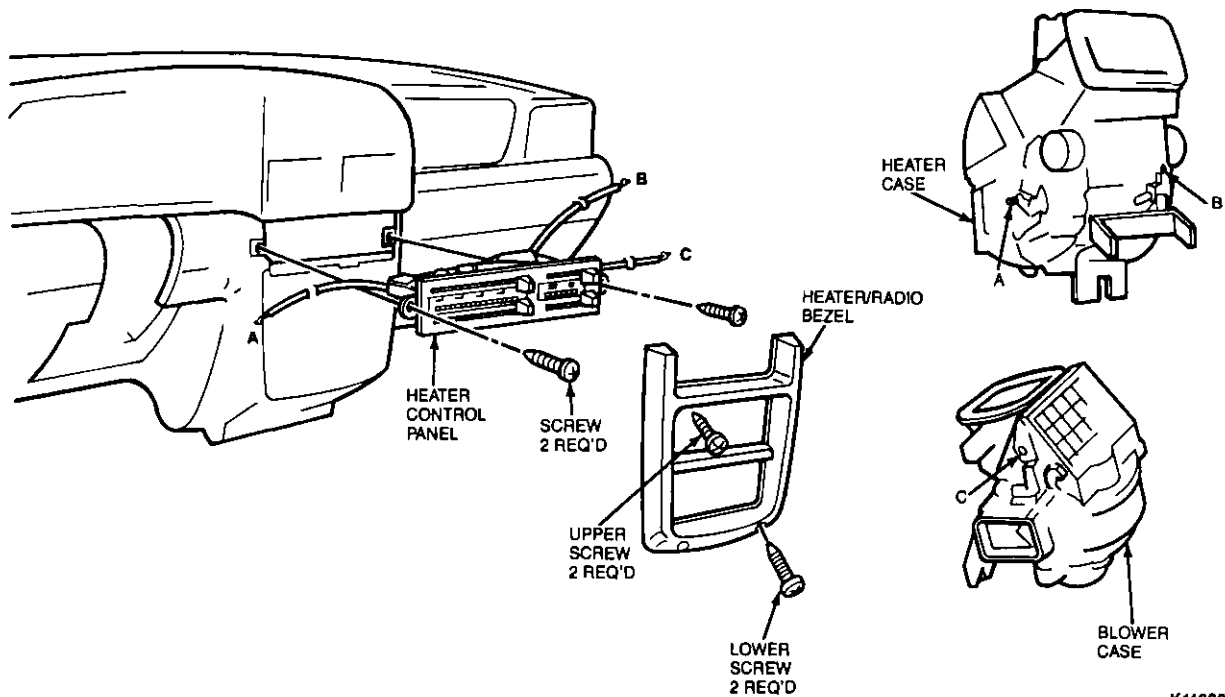

K14828-A

Installation

1. Route cables into instrument panel using care not to kink them and position heater control panel in instrument panel.
2. Connect electrical connectors.
3. Install heater control panel with retaining screws.
4. Connect temperature control cable, function selector cable and air door control cable.
5. Check and adjust control cables, as outlined.
6. Install LH center carpet panel.
7. Install glove compartment upper support.
8. Return glove compartment to closed position.
9. Install heater / radio trim bezel and storage compartment.
10. Connect negative battery cable.
11. Check for proper operation.

Blower Switch**Removal**

NOTE: The heater control panel must be partially removed to gain access to blower switch. The cables do not have to be removed.

1. Partially remove heater control panel as outlined.
2. Remove blower switch knob.
3. Remove blower switch retaining screws and remove blower switch.

Installation

1. Install blower switch to heater control panel with retaining screws.
2. Install blower knob.
3. Install heater control panel, as outlined.

Control Cables**Removal**

1. Remove heater control panel as outlined.
2. Remove cable(s) clamps from housing brace on control panel.

REMOVAL AND INSTALLATION (Continued)

3. Disconnect cable(s) from control panel.

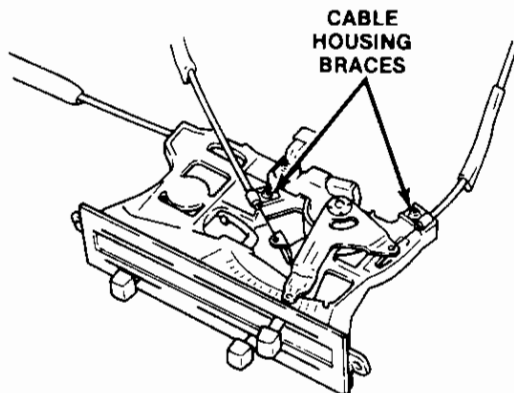
**HEATER CONTROL ASSEMBLY**

K10335-A

Installation

1. Connect cable(s) to control panel.
2. Install cable(s) to housing brace with clamp(s) on control panel.
3. Route cable(s) and install control panel as outlined.
4. Adjust cables as outlined.

Blower Motor**Removal**

1. Disconnect negative battery cable.
2. Disconnect electrical connector at blower motor.
3. Remove three screws retaining motor and cover to blower case.
4. Remove cover, cooling tube and blower motor.
5. Remove nut retaining blower wheel to blower motor. Remove blower wheel.
6. Remove gasket from blower motor.

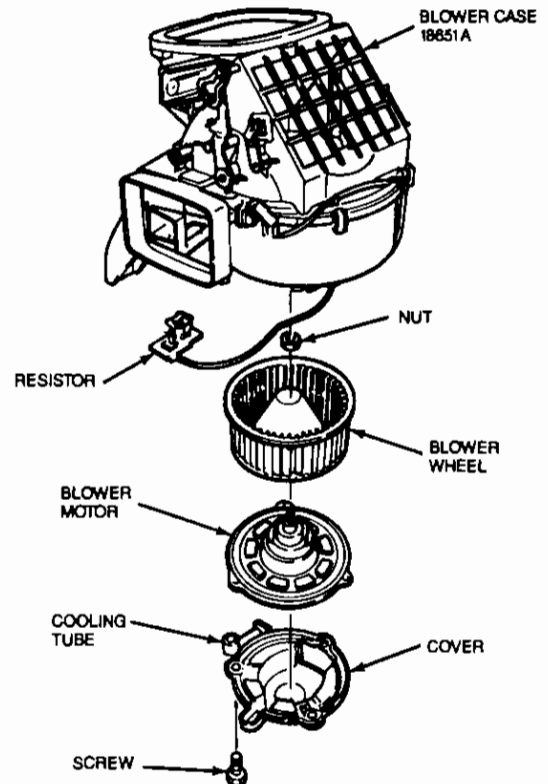

K14830-A

Installation

1. Position gasket onto blower motor.
2. Install blower wheel onto blower motor.
3. Install attaching nut.
4. Position blower motor, cooling tube, and cover into blower case.
5. Install three screws.
6. Connect electrical connector to blower motor.
7. Connect negative battery cable.
8. Check operation of blower motor.

Blower Motor Resistor**Removal**

1. Disconnect negative battery cable.
2. Disconnect electrical connectors at resistor and blower motor.
3. Remove two screws and resistor from blower case.
4. Lower glove compartment below stops.

REMOVAL AND INSTALLATION (Continued)

5. Disconnect blower feed connector.

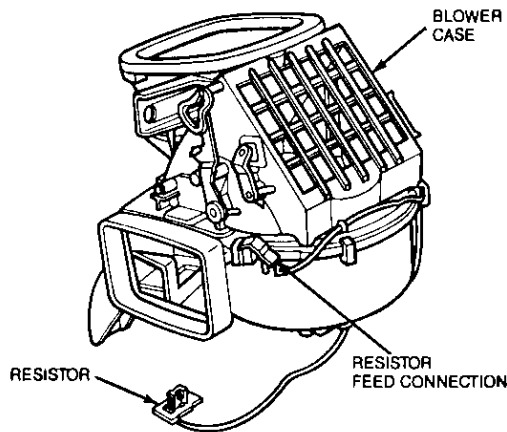

K15016-A

Installation

1. Connect blower feed connector to resistor.
2. Return glove compartment to the closed position.
3. Position resistor into blower case and install two screws.
4. Connect electrical connectors at resistor and blower motor.
5. Connect negative battery cable.
6. Check operation of blower motor.

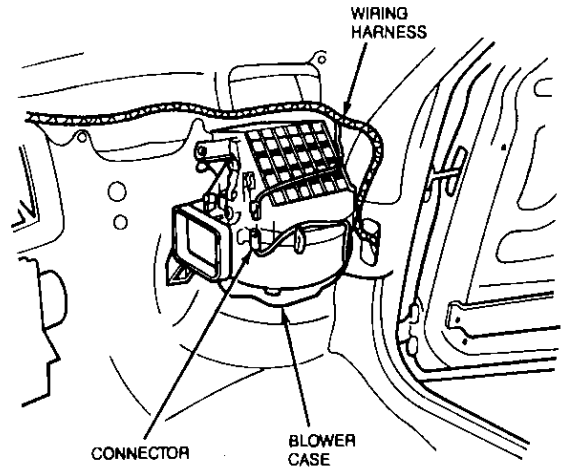

K14819-A

4. Disconnect duct work from blower case.
5. It may be necessary to loosen instrument panel mounting bolts and slightly raise instrument panel assembly to provide clearance for removal. Refer to Section 01-12.
6. Remove three nuts and remove blower case.

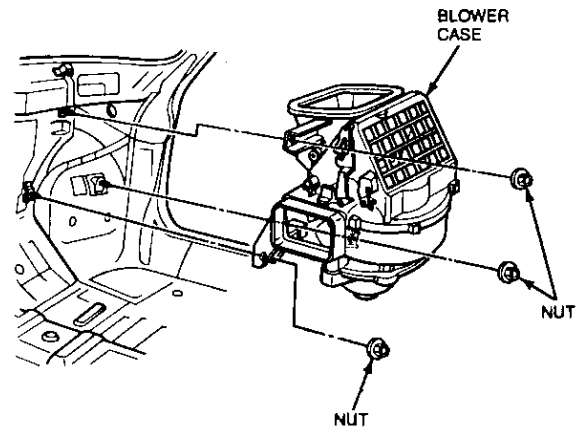

K14877-A

Installation

1. Position blower case and install three nuts. Tighten to 7-10 N·m (5-7 lb-ft).
2. Connect duct work to blower case.

Blower Case Assembly**Removal**

1. Disconnect negative battery cable.
2. Remove air door control cable at blower case as outlined under Air Door Cable, Adjustments.
3. Disconnect electrical connectors from resistor and blower motor. Remove wiring harness from blower case and position out of the way.

REMOVAL AND INSTALLATION (Continued)

3. Connect electrical connectors and fasten wiring harness to blower case.

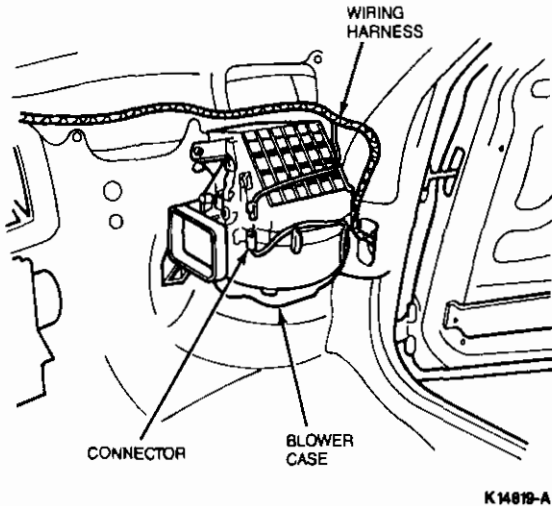

K14819-A

4. Connect and adjust control cable as outlined.
5. Position instrument panel and tighten mounting bolts. Refer to Section 01-12.
6. Connect negative battery cable.
7. Check operation of blower motor and control cable.

Heater Case

WARNING: NEVER REMOVE THE RADIATOR CAP UNDER ANY CONDITIONS WHILE THE ENGINE IS OPERATING. FAILURE TO FOLLOW THESE INSTRUCTIONS COULD RESULT IN DAMAGE TO THE COOLING SYSTEM, ENGINE AND/OR PERSONAL INJURY. TO AVOID HAVING SCALDING HOT COOLANT OR STEAM BLOW OUT OF THE RADIATOR, USE EXTREME CARE WHEN REMOVING THE CAP FROM A HOT RADIATOR. WAIT UNTIL THE ENGINE HAS COOLED, THEN WRAP A THICK CLOTH AROUND THE RADIATOR CAP AND TURN IT SLOWLY TO THE FIRST STOP. STEP BACK WHILE THE PRESSURE IS RELEASED FROM THE COOLING SYSTEM, WHEN CERTAIN ALL PRESSURE HAS BEEN RELEASED, PRESS DOWN ON THE CAP (STILL WITH A CLOTH), TURN AND REMOVE IT.

Removal

1. Remove floor console and instrument panel. Refer to Section 01-12.
2. Drain cooling system. Refer to Section 03-03.
3. Disconnect heater hoses from heater core extension tubes. Plug heater tubes to prevent spilling coolant into passenger compartment.

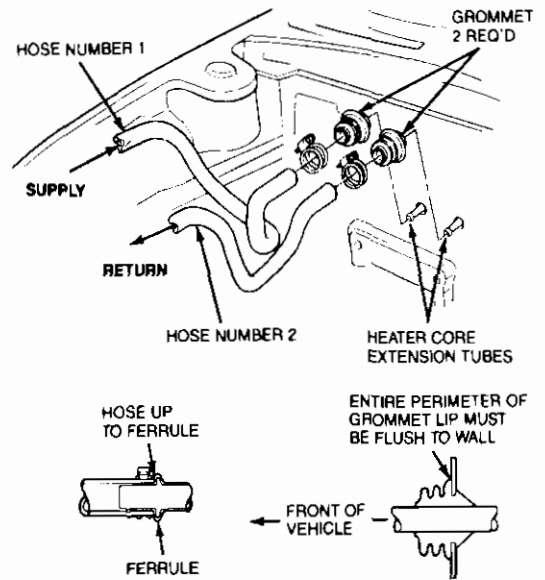

K14832-A

4. Remove plastic rivets and both defroster hoses.
5. Remove main air duct connecting heater case to blower case or air conditioning unit (if equipped).
6. Roll back carpet to gain access to lower duct and lower mounting bolts. It may be necessary to remove carpet fasteners.
7. Disconnect lower duct (rear seat supply) from heater case.

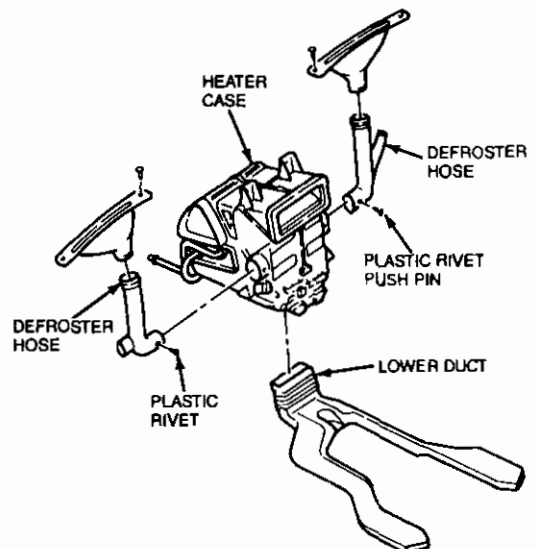

K14831-A

REMOVAL AND INSTALLATION (Continued)

8. Remove cable ends from heater case if still connected.
9. Remove wiring harness from heater case.
10. Remove two lower bolts, two upper nuts, and one center retaining nut from blower case.
11. Remove heater case.

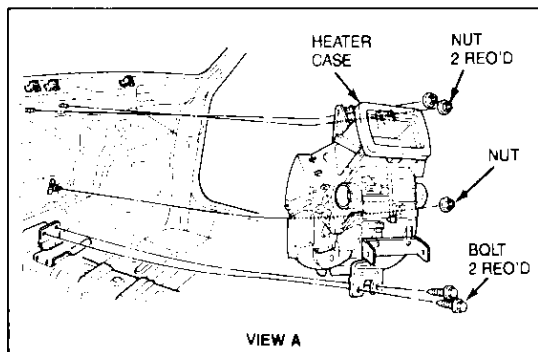
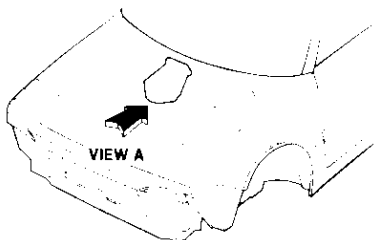

K 4816-A

Installation

1. Position heater case onto mounting studs and guide extension tubes through dash panel. Make sure grommets are sealed around extension tubes.
2. Install two upper nuts, one center retaining nut, and two lower bolts. Tighten all fasteners to 7-10 N·m (5-7 lb-ft).
3. Install lower duct onto heater case.
4. Reposition carpet and install fasteners if removed.
5. Attach wiring harness to heater case.
6. Connect defroster hoses and main air duct to heater case. Install plastic retaining rivets.
7. Connect heater hoses as shown. Tighten clamps to 4-6 N·m (36-53 lb-in).
8. Fill cooling system. Refer to Section 03-03.

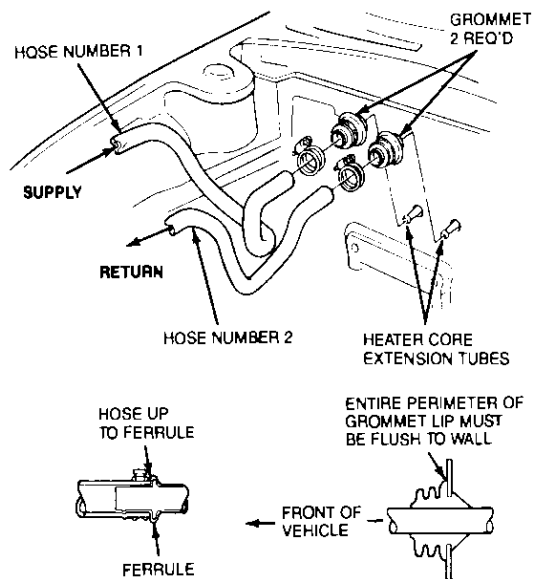

9. Install instrument panel assembly, if removed. Refer to Section 01-12.
10. Connect control cable to heater case and adjust as outlined.
11. Install floor console. Refer to Section 01-12.
12. Operate heater and check for leaks.

Heater Core

WARNING: NEVER REMOVE THE RADIATOR CAP UNDER ANY CONDITIONS WHILE THE ENGINE IS OPERATING. FAILURE TO FOLLOW THESE INSTRUCTIONS COULD RESULT IN DAMAGE TO THE COOLING SYSTEM, ENGINE AND/OR PERSONAL INJURY. TO AVOID HAVING SCALDING HOT COOLANT OR STEAM BLOW OUT OF THE RADIATOR, USE EXTREME CARE WHEN REMOVING THE CAP FROM A HOT RADIATOR. WAIT UNTIL THE ENGINE HAS COOLED, THEN WRAP A THICK CLOTH AROUND THE RADIATOR CAP AND TURN IT SLOWLY TO THE FIRST STOP. STEP BACK WHILE THE PRESSURE IS RELEASED FROM THE COOLING SYSTEM, WHEN CERTAIN ALL PRESSURE HAS BEEN RELEASED, PRESS DOWN ON THE CAP (STILL WITH A CLOTH), TURN AND REMOVE IT.

Removal

1. Drain cooling system. Refer to Section 03-03.
2. Remove heater case as outlined.

REMOVAL AND INSTALLATION (Continued)

3. Disconnect heater hoses from heater core extension tubes as outlined. Cap tubes to prevent spilling coolant into passenger compartment.

4. Remove three screws attaching heater core cover to heater case and remove cover.
5. Remove screws securing tube braces.
6. Loosen clamps and remove extension tubes from heater core. Remove O-ring from outlet tube.
7. Remove heater core by pulling straight out.
8. Remove extension tubes and grommets if necessary.

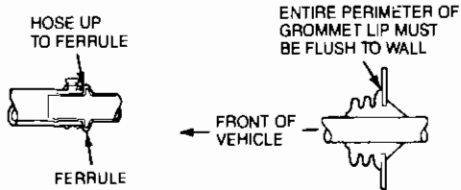
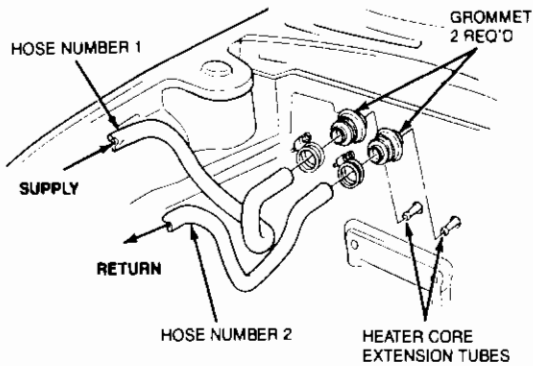

K14832-A

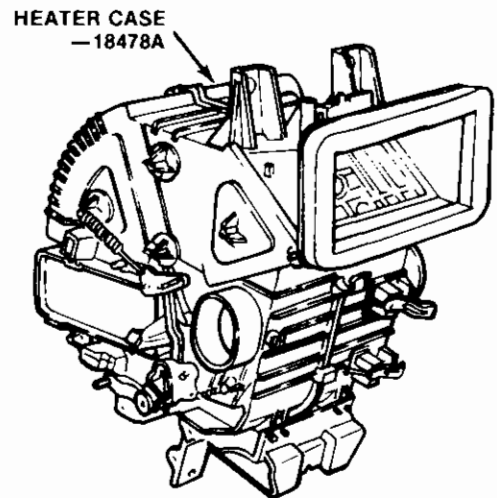
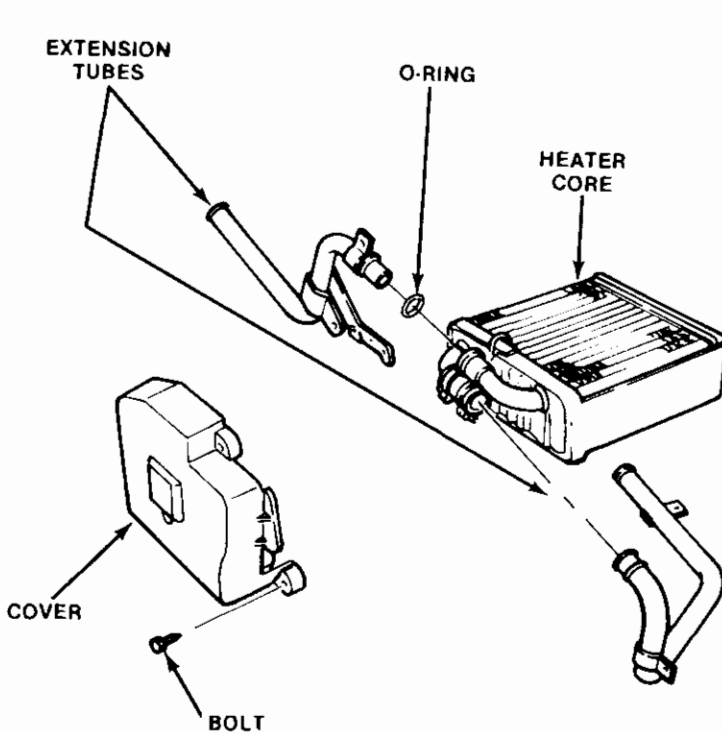

K10336-A

REMOVAL AND INSTALLATION (Continued)**Installation**

1. Install grommets and extension tubes if removed. Make sure grommets are flush with engine compartment wall.

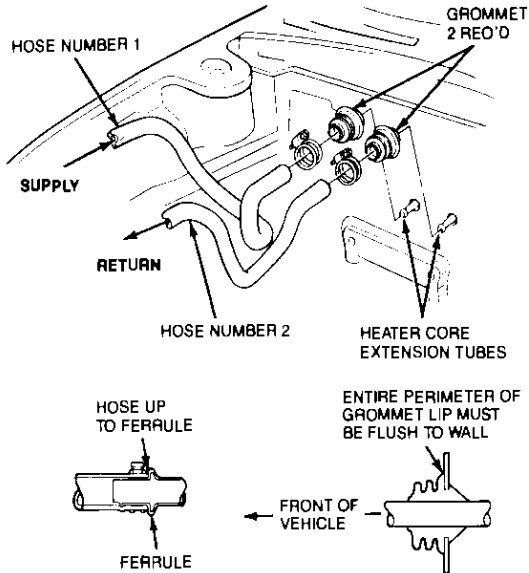

K14832-A

2. Install heater core into heater case.
3. Install a new O-ring onto outlet extension tube.
4. Connect extension tubes to heater core. Tighten clamps securely.
5. Secure extension tube braces with screws.
6. Install heater core cover with three screws.
7. Install heater case as outlined.
8. Connect heater hoses. Tighten clamps to 4-6 N·m (36-53 lb-in).
9. Fill cooling system. Refer to Section 03-03.
10. Operate heater and check for leaks.

3. Compress clamp and remove hose(s) from engine.

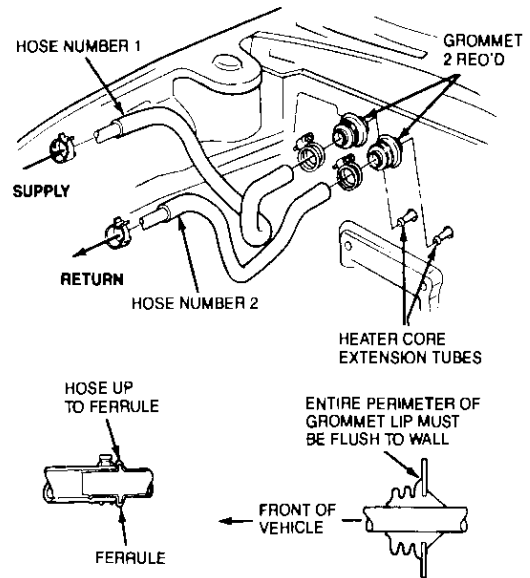

K14815-A

Installation

1. Make sure grommets are in place and flush with engine compartment wall as shown.
2. Place clamps on hose or fitting.
NOTE: Colored dots are used on engine ends of original equipment hoses. Make sure dots face upward when installed to provide proper twist in hose.
3. Install hose and slide all the way up fitting until it reaches ferrule.
4. Install clamps. Tighten screw-type clamps to 4-6 N·m (36-53 lb-in).
5. Fill cooling system. Refer to Section 03-03.
6. Operate engine and heater. Check for leaks.

Heater Hoses

Heater hoses are marked with a colored dot at the engine end of each original equipment hose.

Hose number one (coolant supply to heater) has a red dot for naturally aspirated vehicles and a white dot for turbocharged vehicles.

Hose number two (coolant return to engine) is the same for both engines and uses a green dot.

Removal

1. Drain cooling system. Refer to Section 03-03.
2. Loosen clamps and disconnect heater hose(s) from heater core extension tubes.

Registers, LH Side and Center

The LH side and center registers are attached to the rear of the instrument cluster bezel with screws and washers.

Removal and Installation

1. Remove instrument cluster bezel. Refer to Section 01-12.
2. Remove screws, washers and register(s).

REMOVAL AND INSTALLATION (Continued)

- To install, reverse Removal procedure.

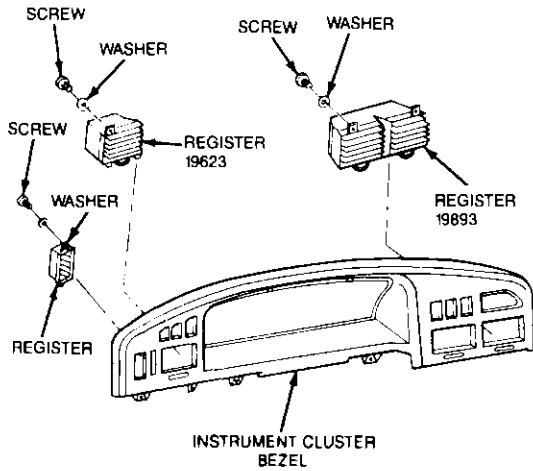

K14633-A

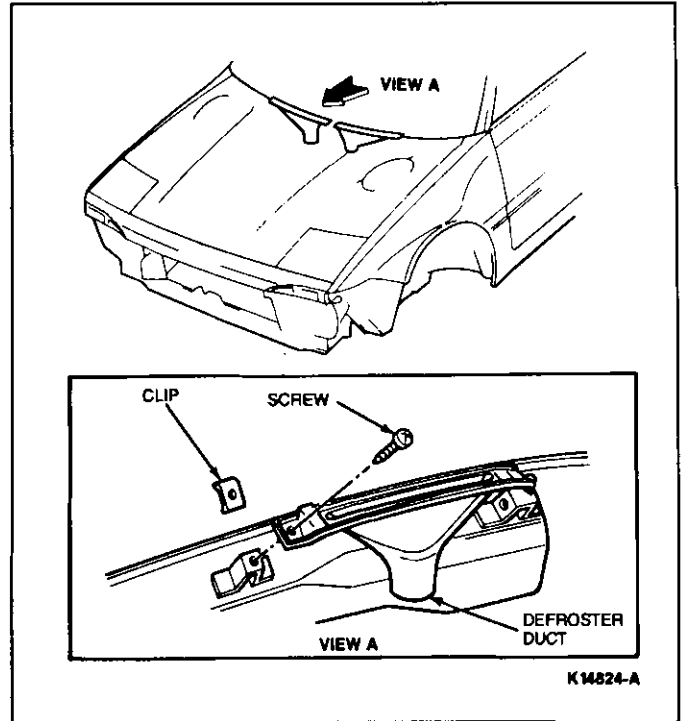

K14624-A

Register, RH Side

Removal and Installation

- Gently pry register from instrument panel.
- Position ducts located behind instrument panel.
- Install register and make sure it is fully connected to ducts.

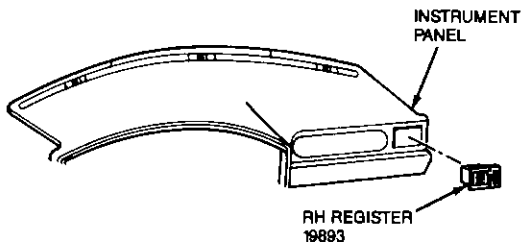

K14634-A

Defroster Tubes and Side Demister Tubes

NOTE: If servicing RH defroster ducts only, they can be serviced through the glove compartment opening after glove compartment support is removed. Refer to Section 01-12.

Removal and Installation

- Remove instrument panel. Refer to Section 01-12.
- Remove defroster and/or demister tubes.
- To install, reverse Removal procedure.

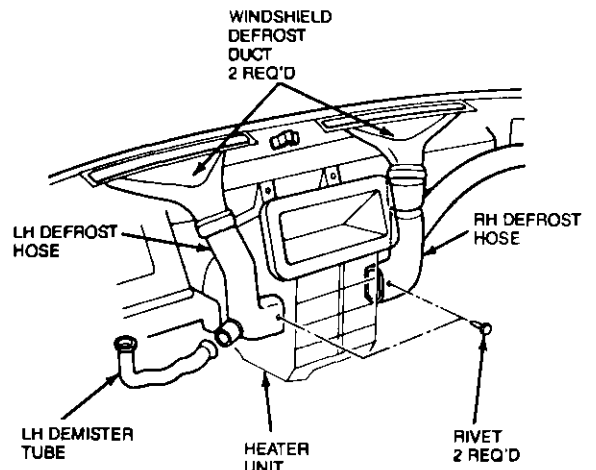

K14620-A

Defroster Ducts

Removal and Installation

- Remove instrument panel. Refer to Section 01-12.
- Remove duct retaining screws and duct(s).
- To install, reverse Removal procedure.

REMOVAL AND INSTALLATION (Continued)**Heat Ducts, Rear Seat****Removal and Installation**

1. Remove carpet. Refer to Section 01-05.
2. Remove duct retaining screw and disconnect from splitter duct.
3. To install, reverse Removal procedure.

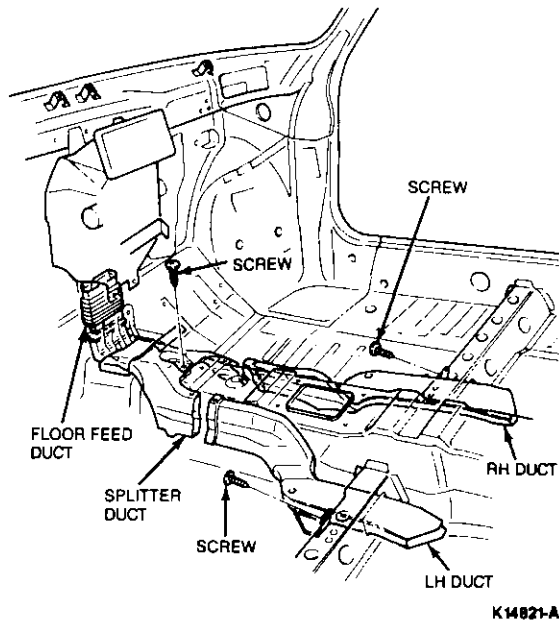

3. Inspect duct seal. Replace, if necessary.
4. To install, reverse Removal procedure.

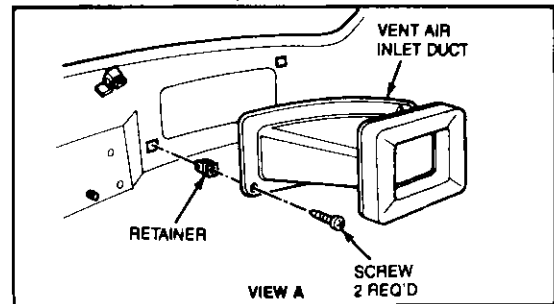
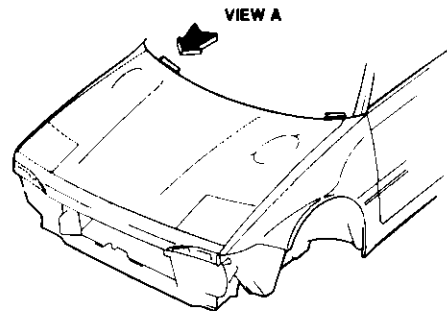
**Air Inlet Duct****Removal and Installation**

1. Remove instrument panel. Refer to Section 01-12.
2. Remove duct.

Instrument Panel Ducts**Removal and Installation**

1. Remove instrument panel. Refer to Section 01-12.
2. Remove retaining screws and ducts, as necessary.

REMOVAL AND INSTALLATION (Continued)

- 3. To install, reverse Removal procedure.

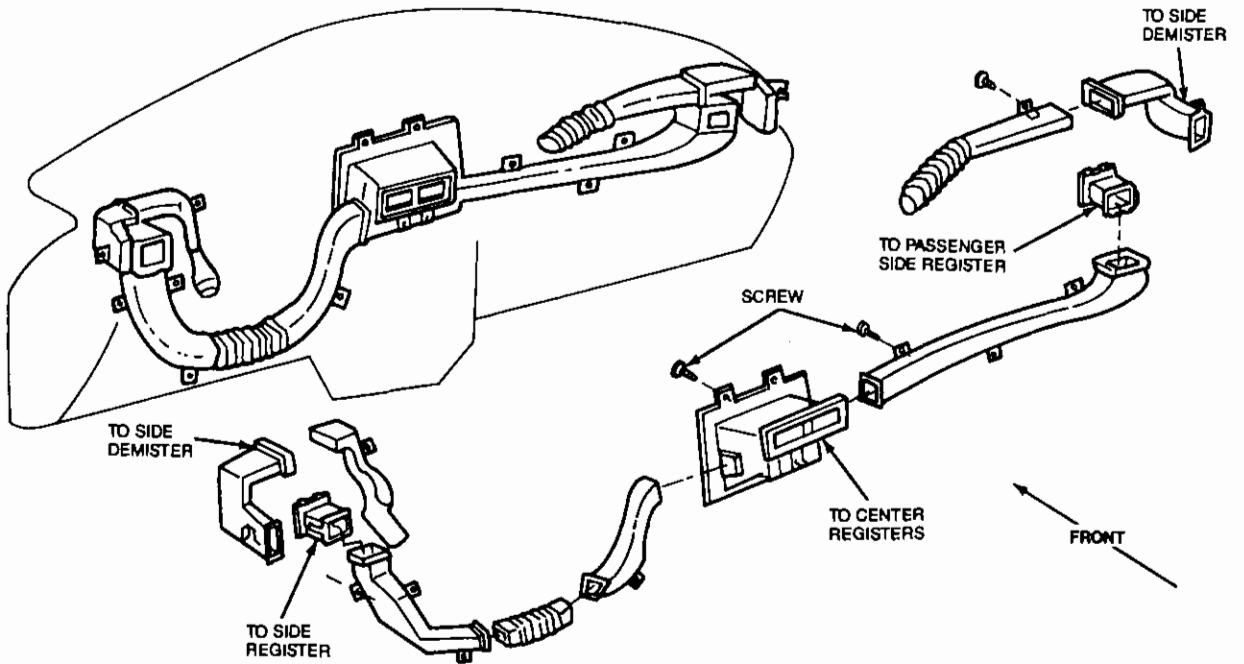

Heater Tube, LH

Removal and Installation

- 1. Remove steering column center trim cover.
- 2. Remove tube.

- 3. To install, reverse Removal procedure.

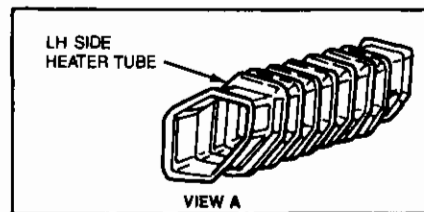
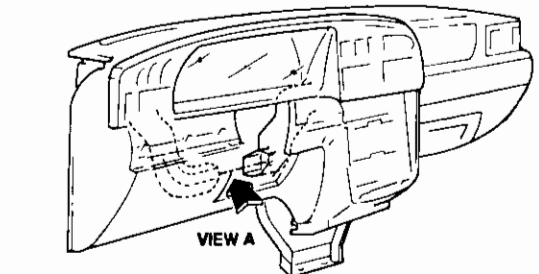

K14822-A

REMOVAL AND INSTALLATION (Continued)

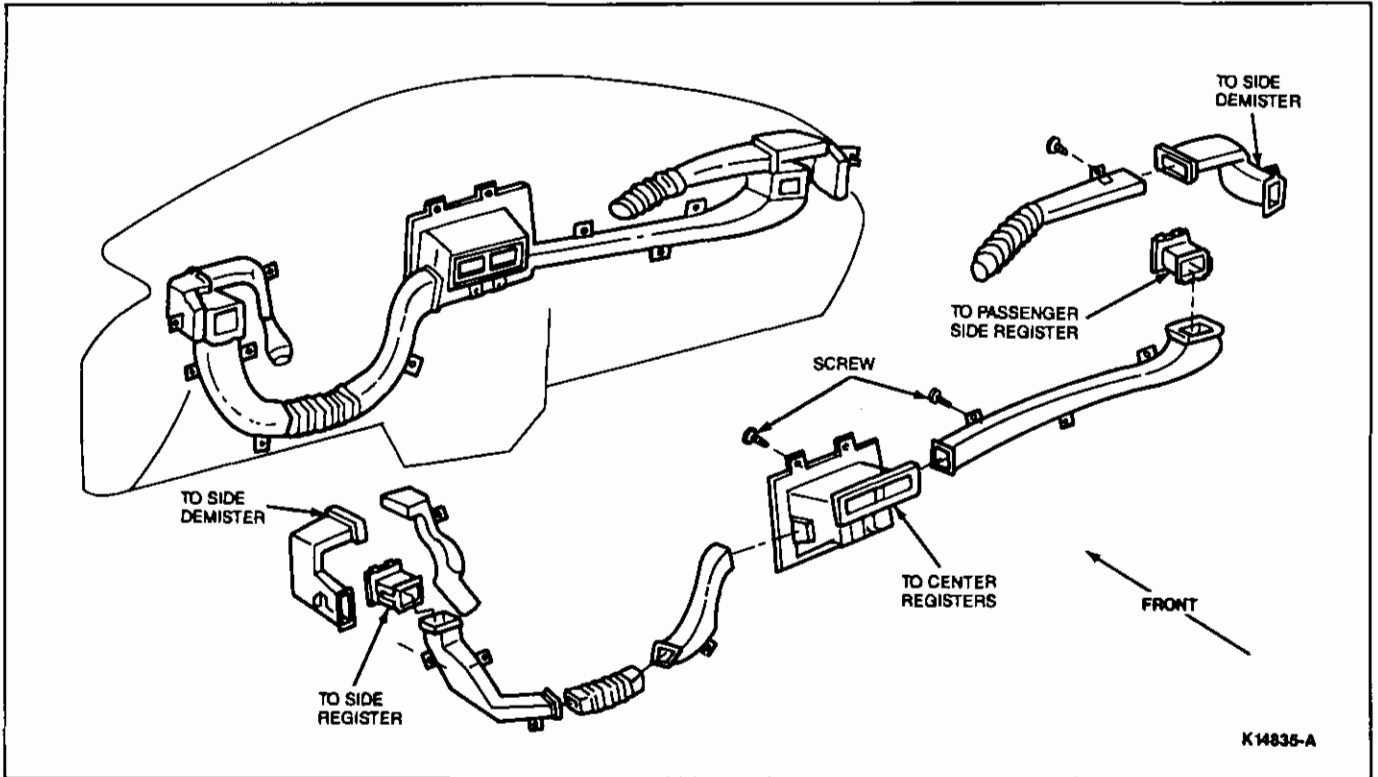

ADJUSTMENTS

Control Cable Adjustment

The control cables should be adjusted every time they are removed to ensure maximum travel of the air control doors.

Function Selector Cable

1. Remove RH center carpet panel.
2. Position function selector lever in DEFROST position.
3. Release cable from housing brace located on side of heater case.
4. With cable end on door lever pin, push door lever down to its extreme stop as shown.
5. Secure cable into cable housing brace.
6. Adjust function selector rod as outlined.

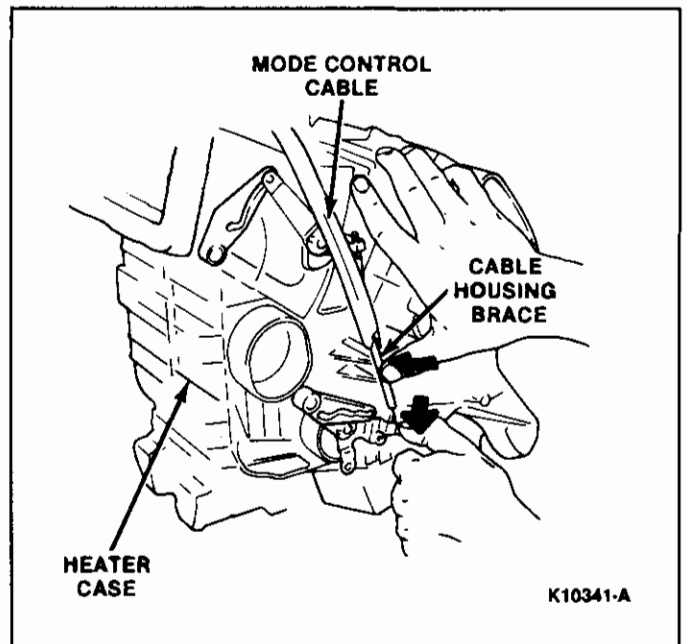
**Function Selector Rod**

1. Remove rod from retaining clip at heater case.
2. Push door lever downward to its extreme stop as shown.
3. Adjust rod to align with clip in heater case lever and secure rod into retaining clip.
4. Check lever for proper operation.

ADJUSTMENTS (Continued)

5. Install RH center carpet panel.

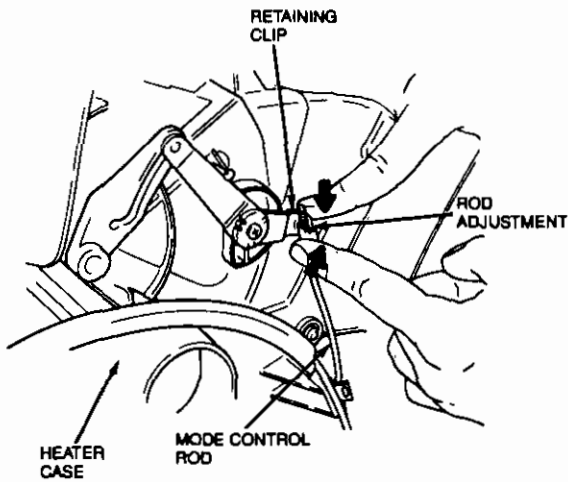

K14827-A

Temperature Control Cable

1. Remove LH center carpet panel.
2. Position temperature control lever in MAX-COLD position.
3. Remove cable from housing brace on side of heater case.
4. With cable end on door lever pin, push door lever down to its extreme stop as shown.
5. Secure cable into housing brace.
6. Check temperature control lever for proper operation.
7. Install LH center carpet panel.

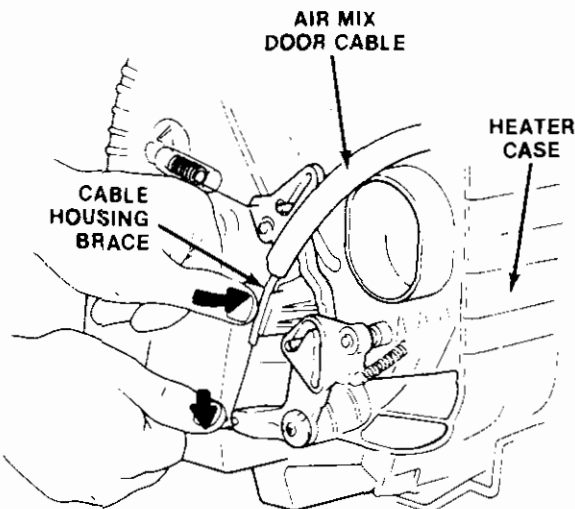

K10340-A

Air Door Control Cable

1. Remove RH center carpet panel.
2. Position air door control lever in FRESH AIR position.
3. Remove cable from housing brace on side of blower case.
4. With cable end on door lever pin, push door lever forward to its extreme stop as shown.
5. Secure cable into housing brace.
6. Check air door control lever for proper operation.
7. Install RH center carpet panel.

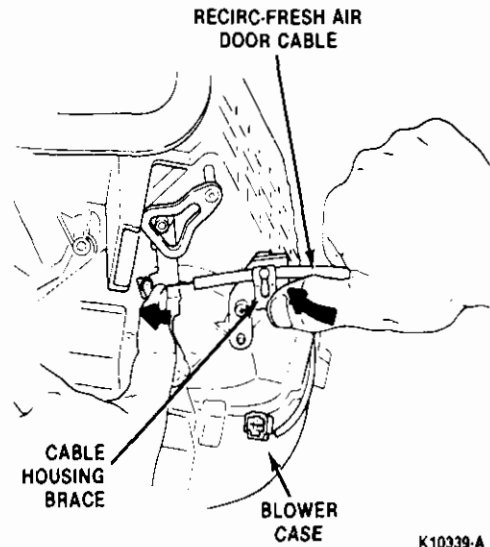

K10339-A

SPECIFICATION

TORQUE SPECIFICATIONS

Description	N·m	Lb·Ft
Blower Case Retaining Nuts	7-10	5-7
Heater Case Retaining Bolts and Nuts	7-10	5-7
Heater Hose Clamps	4-6	35-53 (Lb·In)